

# COMEUP WINCH

POWERSPORTS  
WINCH

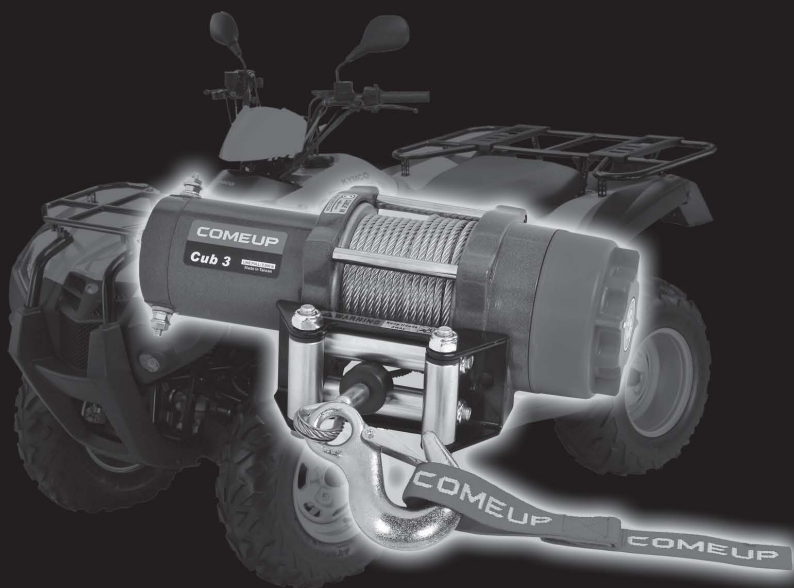

## INSTRUCTION MANUAL



# COMEUP WINCH

## Powersports Winch

Thank you for purchasing a **COMEUP** Winch. This manual covers operation and maintenance of the winch. All information in this publication is based on the latest production information available at the time of printing. We reserve the right to make changes without notice because of continued product improvement.

It has been designed to give safe and dependable service if operated according to the instructions. Read and understand this manual before installation and operation of winch. Careless winch operation can result in serious injury or property damage.

When requesting information or ordering replacement parts, always give the following information:

1. Winch model
2. Serial Number
3. Item. No. and Part Number
4. Part Description



### **WARNING**

1. The winch is rated for intermittent-periodic duty.
2. The winch is not to be used to lift, support or otherwise transport personnel.
3. A minimum of five (5) wraps of rope or of ten (10) wraps of synthetic rope around the drum is necessary to support the rated load.
4. The rated line pull of the winch must be powerful enough to overcome the added resistance caused by whatever the vehicle is stuck in.
5. Never operate the winch under water.
6. Operate the winch cable in and cable out at no load after a winch was penetrated by water.

# **I .Safety Requirement**

WARNING: FAILURE TO READ AND FOLLOW THE SAFETY INSTRUCTIONS IN THIS OWNER'S MANUAL BEFORE INSTALLING OR USING YOUR ATV/UTV WINCH COULD RESULT IN DAMAGE TO YOUR WINCH AND SERIOUS OR FATAL INJURY!!

## **► General Rules**

- ⚠ Check all safety and environmental conditions prior to and during use.
- ⚠ Before use, ensure that you are familiar with all winching performance and operation such as speed & direction.
- ⚠ A wire/synthetic rope should be replaced if it shows signs of excessive wear, broken strands, corrosion or any other defects.
- ⚠ The winches' duty rating is S3 (intermittent – periodic)
- ⚠ If the winch fails to pull a load under normal conditions, stop the operation within 30 seconds otherwise motor damage may occur.
- ⚠ Ensure that the winch is connected to the correct voltage of 12vdc only.
- ⚠ Check that the clutch shifter is in the “Engaged” position during and after use.
- ⚠ Remove the remote control from the winch when not in use.
- ⚠ Do not wrap the wire/synthetic rope around the load and back onto itself. Always use a strap to ensure that the wire/synthetic rope does not fray or kink.
- ⚠ Keep hands and clothes away from the winch, wire/synthetic rope, and fairlead during operation.
- ⚠ Never unplug the remote control and battery leads when winching a load.
- ⚠ To avoid insufficient power when winching a load, the vehicle should be running and in neutral.
- ⚠ When winching a heavy load, lay a heavy blanket or jacket over the wire/synthetic rope near to the hook end
- ⚠ If excessive noise or vibration occurs when running, stop the winch immediately and return it for repair.
- ⚠ If a clutch can't be properly locked in the “Engaged” position, rotate the drum to have the clutch coupled to the gear train
- ⚠ It is very important that the winch shall be mounted on a flat surface, with the wire/synthetic rope feeding form the bottom of the drum.

## II. Main Components

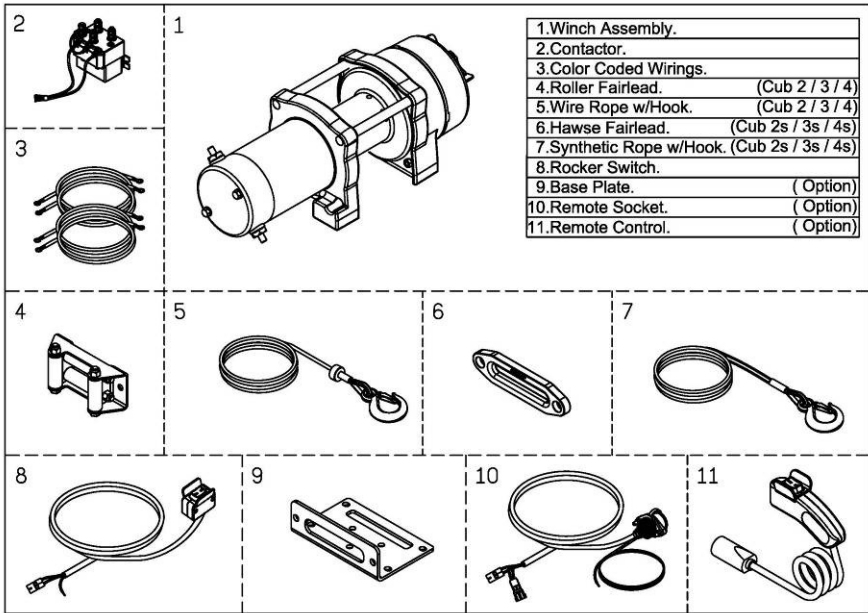

## III. Installation

### ► Complete Kit Installation

To install the complete kit, you need to mount the winch, roller fairlead/hawse fairlead, contactor, rocker switch, remote socket (option) and remote control (option). Read and understand the following instruction to choose the proper mounting locations.

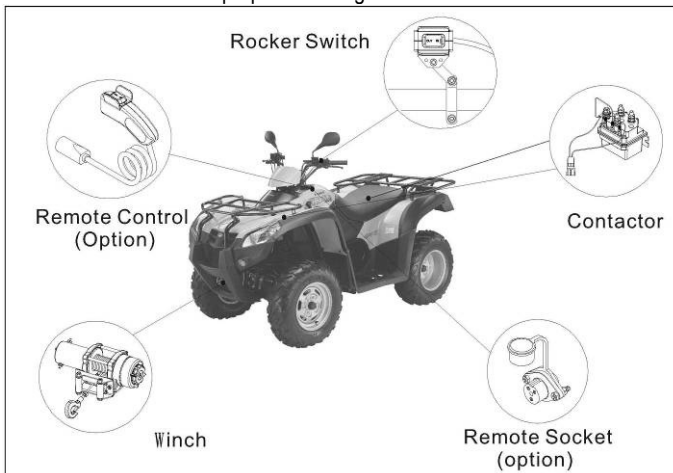

### ► Winch & Roller Fairlead/Hawse Fairlead Mounting

1. It is very important that the winch shall be mounted on a flat hard surface in order to make sure the motor, drum and gearbox housing are aligned correctly.
2. If a different mounting plate is used, the thickness shall be at least 5 mm (3/16"). If different hardware is used, it must be SAE grade 8 minimum.
3. Four (4) M8x 25L Grade 8.8 High Tensile Steel Bolts (supplied) must be used for securing the winch on the mounting plate in order to sustain the loads imposed on the winch mounting.
4. Two (2) M8 x 20L Grade 8.8 High Tensile Steel Bolts (supplied) must be used for securing the roller/hawse fairlead on the mounting plate.

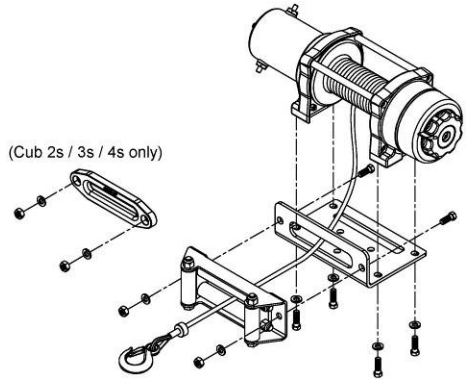

### ► Contactor Mounting

1. It disconnects your winch from the power source when the vehicle is not in use.
2. It should be mounted close to the battery and keep the location from all metal structures.

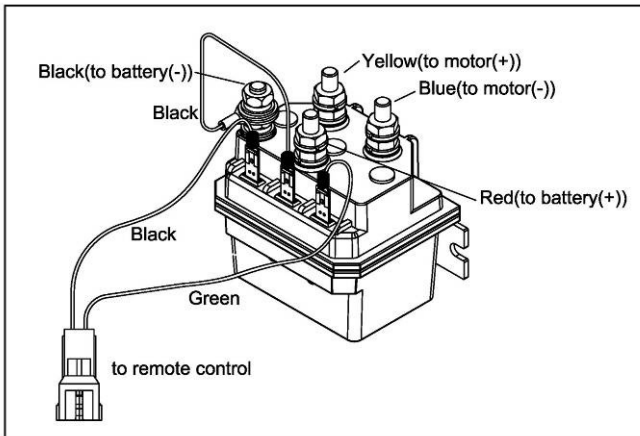

### ► Battery Recommendations

A fully charged battery and good connections are essential for the proper operation of your winch. The minimum requirement for battery is 500 cold cranking amp.

► **Remote Socket Mounting (Option)**

1. Determine the mounting location for the remote socket.
2. Drill three holes on a plate and install.

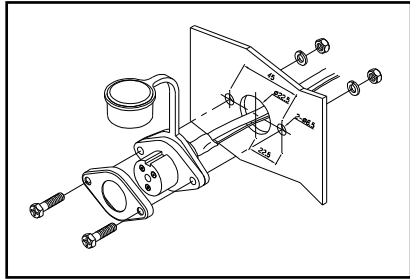

► **Rocker Switch Mounting**

Handlebar mounted rocker switch can be operated without removing your hand from the grip.

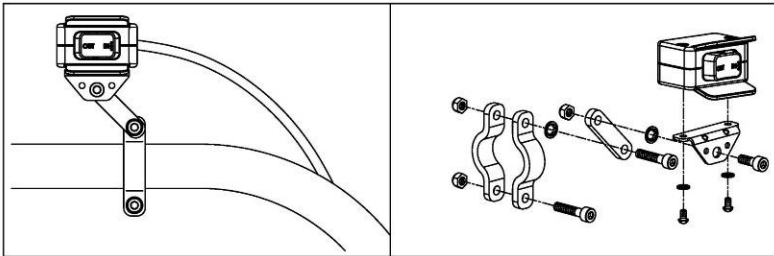

► **Wiring Diagram**

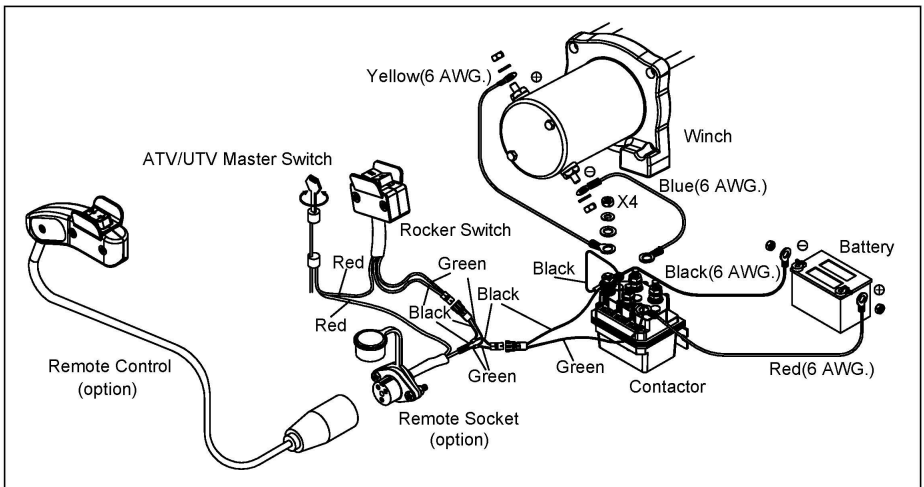

## IV. Operation

### ► Cable In and Out

- 1). To "Winch or Cable - Out", rocker → out
  - 2). To "Winch or Cable - In", rocker ← in
- To stop winching, release the rocker

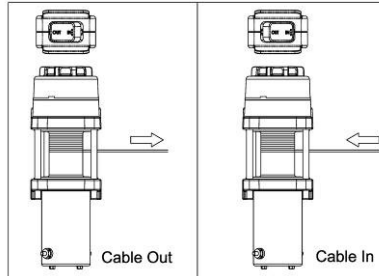
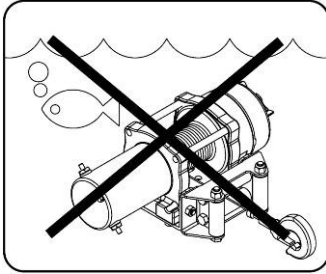

### ► Clutch Function

The clutch allows rapid pay-out of the wire/synthetic rope for hooking onto a load or anchor points and is operated by a clutch shifter located on the end of the winch.

- 1). To engage the clutch, turn the clutch shifter counter-clockwise to the "Engaged" position. The winch is now ready for pulling.
- 2). To disengage the clutch, turn the clutch shifter clockwise to the "Disengaged" position. Wire/synthetic rope can now be free spooled off the drum.

(Cub Series)



(Engaged)

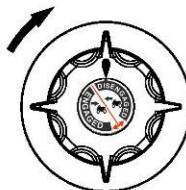

(Disengaged)

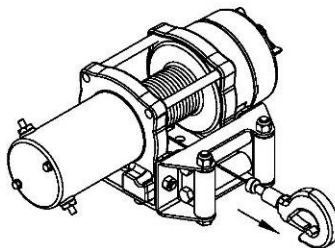

## **V. Maintenance**

### **► Wire/Synthetic Rope Replacement**

Before installing a new wire/synthetic rope, wrap the end of the wire/synthetic rope with tape to prevent fraying. Wind the wire/synthetic rope on the drum by pulling a force to keep the tension constant. Never use a wire/synthetic rope of a different size or material.

- 1). Disengage the clutch.
- 2). Have horizontal roller and bolts apart from the roller fairlead, then Spool the old wire/synthetic rope, and then remove it from the drum.
- 3). Place the replacement wire/synthetic rope through the roller/hawse fairlead throat, pass it below the drum. Insert rope into pocket opening and through wedge pocket.
- 4). Loop rope end around wedge and feed rope back through wedge pocket.
- 5). Once slack is taken up, the wire/synthetic rope is properly installed.
- 6). Tighten the horizontal roller of the roller fairlead and bolts of the roller/hawse fairlead
- 7). Wear leather gloves and use a strap when guiding the wire/synthetic rope off the drum.
- 8). Rewind wire/synthetic rope on the drum correctly, it is necessary to keep a slight load on the wire/synthetic rope while cable in.

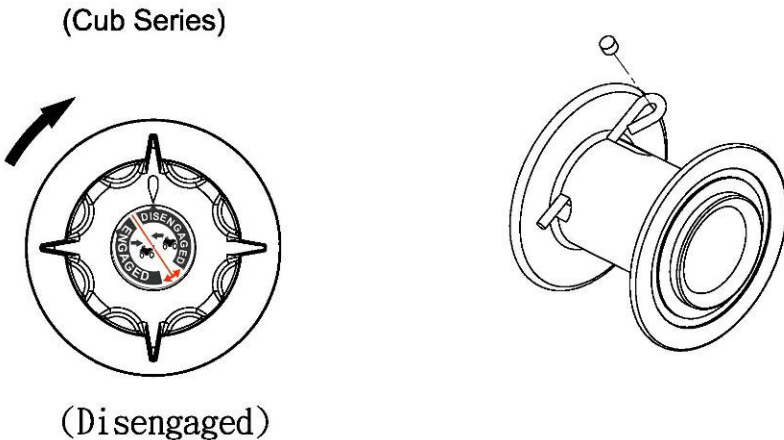

### **► Lubrication**

All moving parts in the winch are permanently lubricated at the time of kit. Under normal conditions factory lubrication will suffice. If re-lubrication is necessary after repair, please use marine type grease.



► **Maintenance Schedule**

Carry out all inspections below on schedule. All inspections are performed by Daily, Monthly and Quarterly basis. Clean all connections because corrosion on electrical connections will reduce performance or may cause a short.

Classification of check			Item	Checking method	Checking reference	
Daily	Periodical					
	Monthly	Quarterly				
		○	Complete winch	Operate the winch in and out	Minimum corrosion of the internal motor components	
○			Installation	Mounting bolts & alignment	Bolts tension & wear	Tightened and aligned
○			Control / Switch	Working	Manual	Reasonable actuation
		○		Wearing in contact points	Visual	Free of wear or damage
○			Wire/ Synthetic rope	Broken strands	Visual, measuring	Less than 10%
○	○			Decrease in rope diameter	Visual, measuring	7% of nominal diameter max
○				Deforming or corrosion and fastening	Visual	No existence of abnormalities
		○	Clutch kit	Damaged clutch kit	Visual evidence of wear	Free of wear or damage.
		○	Motor	Staining, damage	Visual evidence of wear	No existence of abnormalities
		○	Brake	Wearing of lining	Visual evidence of wear	Free of wear or damage
○				Performance	Visual	Reasonable actuation
		○	Gear train	Damage, wearing	Visual evidence of wear	Free of wear or damage and distortion

## **VI. Trouble Shooting**

When the winch fails to operate after several attempts, or if there is any fault operation while winching, check followings.

<b>Symptom</b>	<b>Possible Cause</b>	<b>Remedy</b>
Winch will not operate	Cut circuit or loosing	Check battery lead.
	Weak battery or insufficient power	Recharge or replace battery
	Damaged over-load protector	Replace over-load protector
	Loose connection of wirings	Checking all wirings
	Damaged or stuck contactor	Replace contactor
	Defective remote control	Check winch operation with an auxiliary switch
	Damaged motor	Replace motor
Motor runs in one direction.	Broken wiring or bad connection	Reconnect or replace wiring
	Damaged or stuck contactor	Replace contactor
	Switch inoperative	Replace switch
	Drop or loosen wiring	Replace wiring and tighten.
Drum will not clutch	Clutch does not disengage	Engaged clutch
	Damaged brake or clutch kit	Replace brake or clutch kit
	Damaged drum bushing	Replace drum bushing
	Damaged gear box	Replace gear box
No brake	Damaged or inoperative pressed spring	Replace pressed spring
	Disengaged clutch	Engaged
	Damaged 3 <sup>rd</sup> stage carrier	Replace 3 <sup>rd</sup> stage carrier
	Damaged 1 <sup>st</sup> shaft	Replace 1 <sup>st</sup> shaft
Brake distance is too long	Worn or damaged brake	Replace or adjust brake
Winch runs in opposite direction	Motor leads crossed	Reverse electrical connections to motor
	Contactor control crossed	Reverse black and red wires on the contactor
	Remote control or rocker switch crossed	Reverse electrical connections
Motor runs extremely hot	Long period of operation	Stop operation to have it cooled
	Over-load	Reduce load
	Damaged or inoperative brake	Replace or repair brake

# COMEUP WINCH

## COMEUP INDUSTRIES INC.

No.112, Nanyang St., Xizhi Dist., New Taipei City, Taiwan 22152

Tel: +886-2-2694-7011 / Fax: +886-2-2694-7053

Email: [winch@comeup.com.tw](mailto:winch@comeup.com.tw)

<http://www.comeupwinch.com>

PN 881407 Ver:05

Specifications subject to change without notice